

REVISIONS					
P	LTR	DESCRIPTION	DATE	DWN	APVD
	D	REVISED< ECR-05-016169 >	06, OCT, '05	YD.	JK
	E	REVISED< ECR-06-022709 >	30, JUN, '06	IS	JK
	F	REVISED< ECR-07-000190 >	04, JAN, '07	IS	JK
	F1	REVISED< ECR-11-008995 >	28, APR, '11	YM	HG
	G	REVISED< ECR-12-013083 >	18, JUN, '12	JM	HG
	G1	REVISED< ECR-14-014192 >	29, SEP, '14	JM	HG

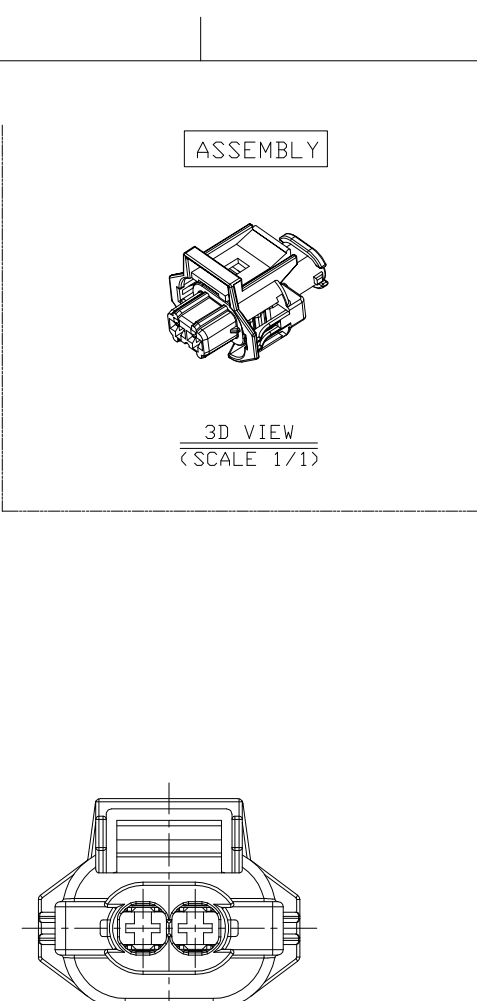

ACCESSORIES DRAWING
 ① DBL HSG : P/N:936103
 SCALE : 2/1

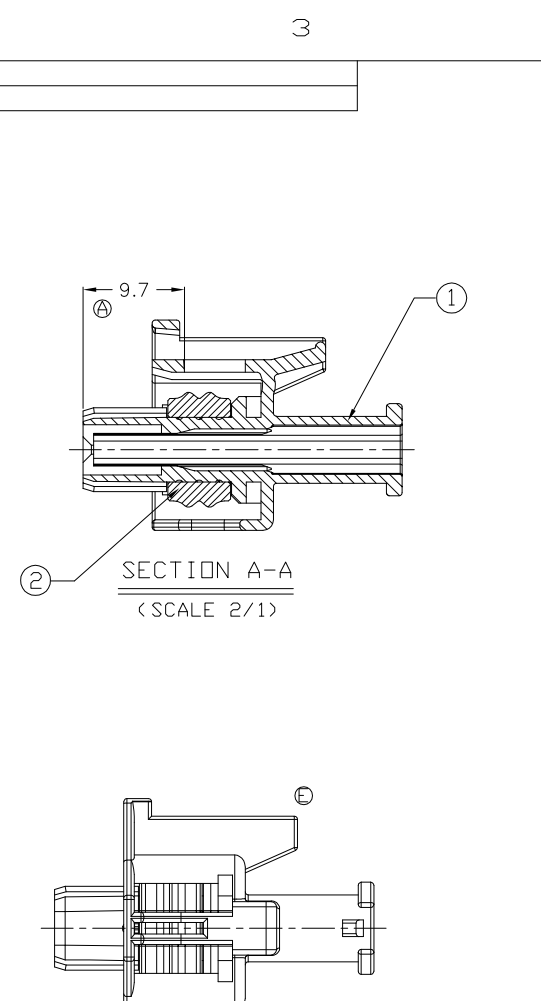
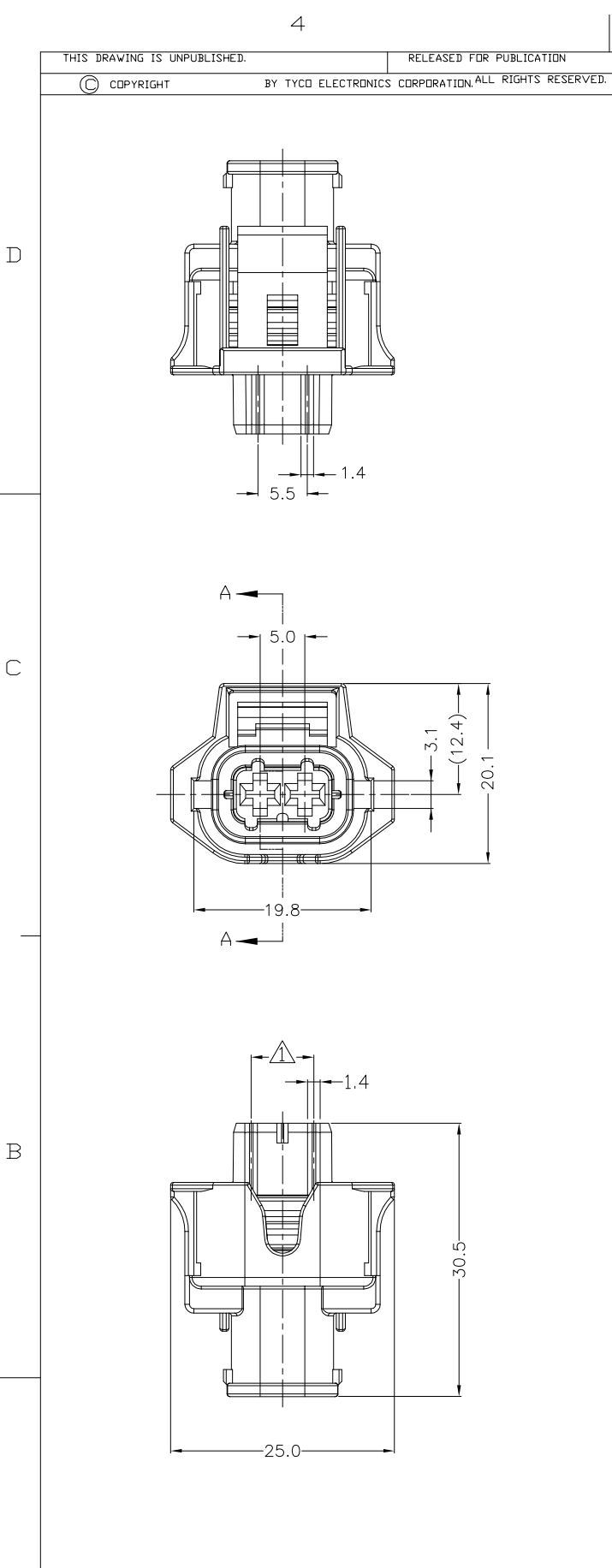
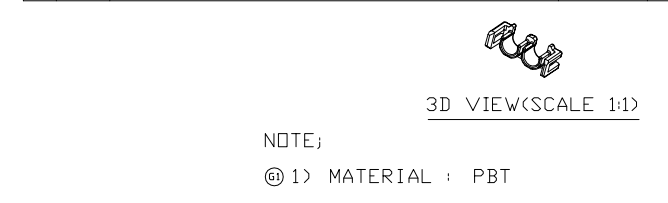
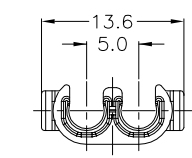
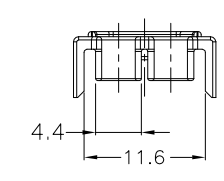

NOTE;
 ①) MATERIAL : PBT

② COVER HSG : P/N:936111
 SCALE : 2/1

NOTE;
 ①) MATERIAL : NYLON 66
 2) CORRUGATOR DIAMETER : $\phi 7.0$

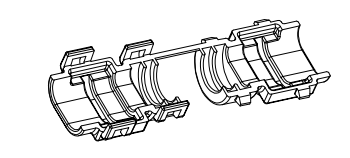

3D VIEW<SCALE 1:1>

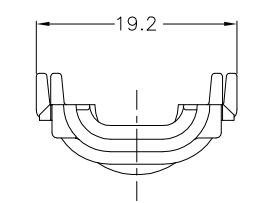
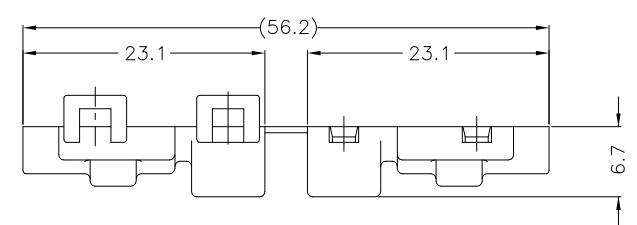

4. APPLIED RECEPTACLE CONTACT P/N:

DESCRIPTION	2.8mm SENSOR-FLAT RECEPTACLE	
Part NO.	967542	967543
WIRE SIZE(mm ²)	0.5 ~ 1.0	1.25 ~ 2.5

5. APPLIED WIRE SEAL P/N:

DESCRIPTION	SINGLE-WIRE SEAL(5mm Hole)	
Part NO.	828904	828905
INSULATION DIA. (φ)	1.2 ~ 2.1mm	2.2 ~ 3.0mm

(TABLE 1)

CODE I : 0-936059-1	CODE II : 1-936059-1 CODE II : 1-936059-3
7.0	4.0
CODE III : 2-936059-1	CODE IV : T. B. D
5.5	3.5

NOTE;
 ① CODING IS AS FOLLOWS; SEE TABLE 1.
 2. 0.15 MAX. WARPAGE AND 0.2 MAX. FLASH ARE PERMISSIBLE
 3. SURFACE DEFECTS ARE NOT ACCEPTABLE AS FOLLOWS: SINK, WELD LINES, HAIRCRACKS, STAINS & SCORES

Q' TY	COLOR	MATERIAL	DESCRIPTION	P/N	NO
1	SIGNAL GRAY	SILICON<LSR>	INNER SEAL	936800-3	2
1	ULTRAMARINE BLUE	SILICON	INNER SEAL	936800-2	2
1	RED ORANGE	SILICON	INNER SEAL	936800-1	2
1	BLACK	PA 66 GF15	PLUG HSG	3-936102-1	1
1	BLACK	PA 66 GF15	PLUG HSG	2-936102-1	1
1	DARK GRAY	PA 66 GF15	PLUG HSG	1-936102-3	1
1	BLACK	PA 66 GF15	PLUG HSG	1-936102-1	1
1	BLACK	PA 66 GF15	PLUG HSG	936102-1	1

ASSEMBLY P/N 3-936059-1 2-936059-1 1-936059-3 1-936059-1 936059-2 936059-1	DIMENSIONS: MM		TOLERANCES UNLESS OTHERWISE SPECIFIED: 0 <XX<10 ± 0.2 10<XX<30 ± 0.25 30<XX ± 0.3 ANGLES ± 3°		DWN : JM JEON CHK : JW JUNG APVD : HG CHO PRODUCT SPEC APPLICATION SPEC 114-18144 WEIGHT CUSTOMER DRAWING	TE connectivity NAME 2.8mm SEALED 2P PLUG ASSEMBLY (FLAT SENSOR CONNECTOR) SIZE CAGE CODE DRAWING NO A200779 936059 RESTRICTED TO
	3rd ANGLE PROJECTION		FINISH			
	MATERIAL		SEE TABLE			
	SCALE 2/1		SHEET 1 OF 1			